

Tank Dimensions (mm)

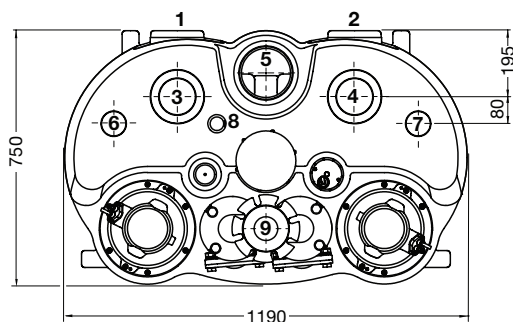

Inlet Diameters

Ø	(mm)
DN 70	+0.2 ø75 -1.0
DN 100	+0.3 ø110 -1.0
DN 150	+0.4 ø160 -1.5

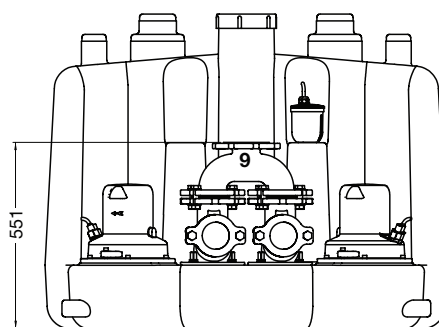
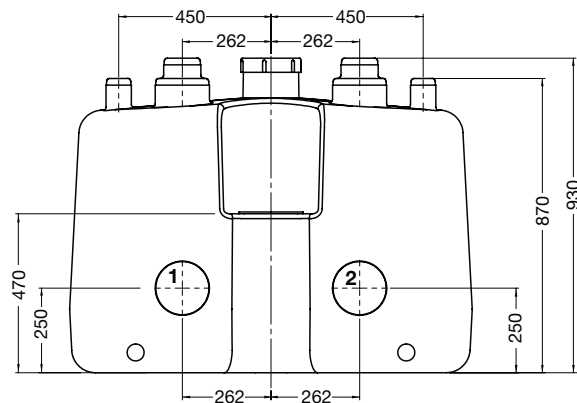
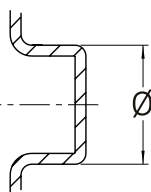

Connections

1. Inflow DN 150
2. Inflow DN 150
3. Inflow DN 100/150
4. Inflow DN 100/150
5. Inflow DN 150 (variable with 90° elbow)
6. Vent/Inflow DN 70
7. Vent/Inflow DN 70
8. Inflow/Hand membrane pump DN 40
9. Discharge flange DN 80

Note:

Rooms for sewage lifting stations must be large enough that a working area of at least 60 cm width or height is available around all parts which have to be operated or maintained. A pump sump should be provided for dewatering of the room itself.