

## DRIMASTER 365 - POSITIVE INPUT VENTILATION (PIV)

A UNIQUE, LOW ENERGY, ALL YEAR ROUND VENTILATION UNIT.



## BENEFITS

### EXTREMELY LOW POWER CONSUMPTION

Average approximately 0.16 watts / litre / second and solar gains up to 550kW / hr / year.

### EASY INSTALLATION & VERY LOW MAINTENANCE REQUIREMENT

Filter clean or replacement every 5 years.

### SIGNIFICANTLY IMPROVES INDOOR AIR QUALITY

Using positive input ventilation removes indoor air pollutants such as carbon monoxide and keeps out traffic fumes, pollen and outdoor pollutants.

### INTELLIGENT HEAT RECOVERY

Twin sensors optimise energy efficiency, adjusting settings to provide increased comfort.

### COMPLIES WITH THE BUILDING REGULATION VENTILATION REQUIREMENTS

Meets Part F&L England and Wales and contributes towards 'conservation of fuel and power'. (Please refer to BBA Certificate).

### RADON GAS CONTROL

Helps reduce and maintain radon gas levels.

### CREATES A HEALTHIER LIVING ENVIRONMENT

High efficiency G4 filters removes up to 95% dust particles.

### FIT & FORGET OPERATION

Fully automatic when airflow set on installation.

### FIRE DAMPER AND DIFFUSER FOR 3-STOREY ACCOMMODATION AVAILABLE

The diffuser is manufactured from aluminium and powder coated to an off white finish (RAL 9003). Product code Drimaster-3S.

### HEALTH

Clinically proven to help allergy and asthma sufferers.

### SECURITY

Allows occupants to keep windows closed for added security and reduce noise levels.

### OPTIONAL BOOST FACILITY

When additional ventilation is required i.e. cooking odours etc.

### OPTIONAL HEATER FACILITY

To provide additional heat to the incoming air if required i.e. during very cold weather.

### WARRANTY

5 year warranty for peace of mind.

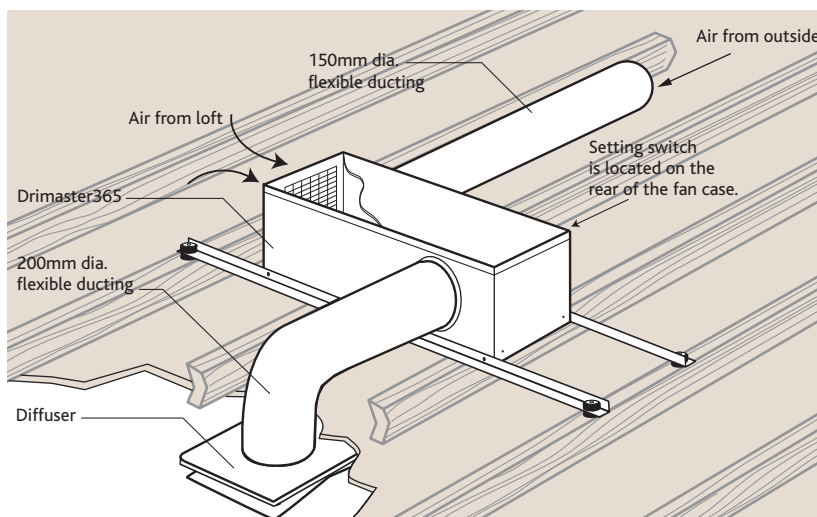
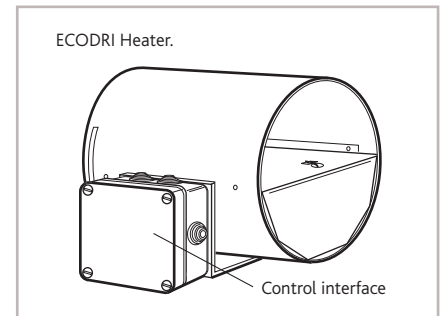

Unit mounted on roof joists using two "L" shape metal brackets and AV mounts supplied with unit.



Remote Sensor.



G4 Filter.



Boost Switch.



Ceiling Diffuser.

**DRIMASTER365**

Drimaster365 is a unique low energy, loft mounted Positive Input Ventilation unit providing whole home ventilation all year round. The unit is totally automatic and intelligently decides what location to supply the air from. It utilises the solar gain within the loft during the colder months subsequently, overcomes excessive solar gains during the warmer months.

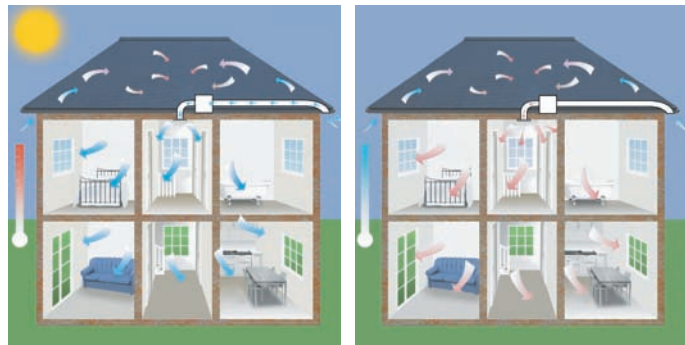

**SUMMER** - If the loft temperature is above 24°C air is drawn directly from outside, to provide background ventilation. In addition a boost switch is supplied to increase airflow when required.

**WINTER** - During the colder months tempered air is drawn from the loft space taking advantage of solar gain combined with the heat conducted through the ceiling of the home.

**THE BOOST SWITCH**

Drimaster365 air volumes can be boosted to obtain maximum ventilation by the operation of a boost switch which is supplied with the unit. By switching the unit to boost all other settings are over-ridden.

**INSTALLATION KITS FOR DRIMASTER365**

Please note: Full details of the installation materials supplied with the unit, and optional installation materials, not supplied with the unit, which can be purchased separately from Nuaire are listed in the installation manual, leaflet number 671429.

**\*Note: 3 storey properties must be fitted with an aluminium diffuser.**

**DIMENSIONS (MM)**

Drimaster365 unit.

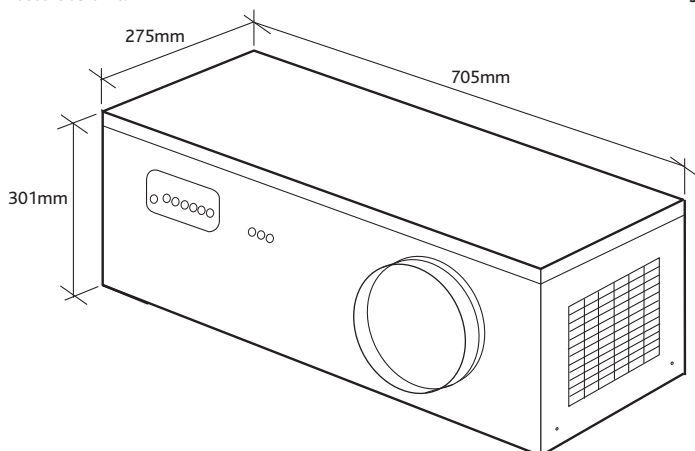

**WIRING**

Please note: the electrical connection of the unit must be carried out by a qualified electrician.

**Electrical details:-**

- Voltage:** 240V 1ph 50Hz
- Consumption:** 2W (min) 24W (max)
- Fuse rating:** 3 Amp

Note: This unit must be earthed.

The three core cable from the mains power supply should be connected to a fixed wiring installation, via a fused isolator, in accordance with current IEE wiring regulations.

**AIR DIFFUSER WITH FIRE DAMPER**

For use in stairwells of three storey properties, the optional powder-coated aluminium diffuser with 'Fireblock' provides 1 hour of fire resistance in accordance with BS476 Part 20 and ISO834.

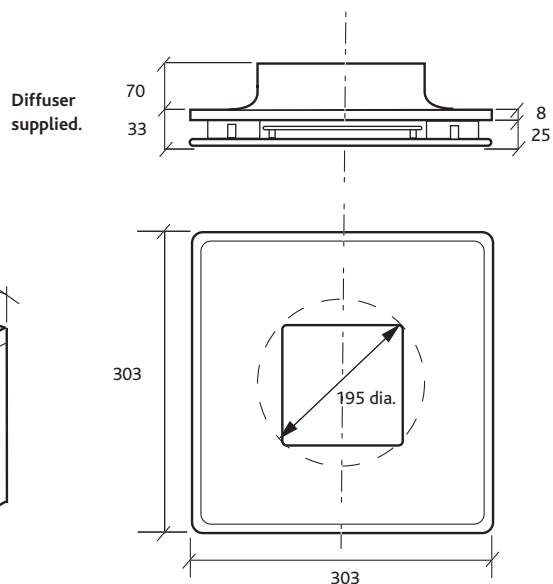
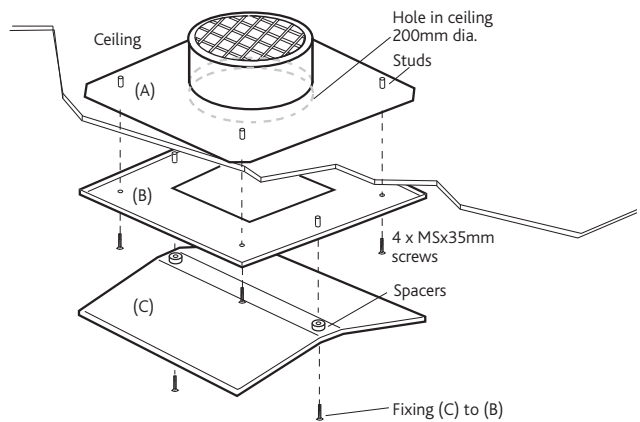

## CONSULTANTS SPECIFICATION

### FAN DESCRIPTION

Nuaire Drimaster365 ultra low energy positive input ventilation unit.

The unit casing shall be manufactured from thermally lined pre-painted steel.

The casing shall have an easily removable panel to allow access for maintenance. The unit shall incorporate a filter of G4 grade with an area of approximately 0.47m<sup>2</sup>.

The unit shall incorporate a forward curved centrifugal impeller and high efficiency brushless DC motor fitted with sealed for life, self lubricating bearings and locked rotor protection.

The unit shall be supplied with a purpose designed polymer diffuser for efficient, directable air input using side blanking pieces supplied. The diffuser design shall minimise the accumulation of any condensate run off that may occur in the event of power to the unit being switched off.

The ducting between the unit and the diffuser is supplied with unit.

The unit shall incorporate 6 volume control settings for maximum flexibility and occupant comfort. The unit is fully automatic. If the loft temperature is below 24°C then the unit will draw fresh air from the loft. If the loft temperature is above 24°C then cool fresh air will be drawn from outside the dwelling.

The unit shall incorporate two air inlets, one draws air from the loft, the other from outside via a 150mm dia. spigot.

The unit can be boosted to obtain maximum ventilation by the operation of a boost switch (supplied).

An internal monitor shall record the unit's operational time.

The unit shall be offered with a 5 year warranty.

For information on reducing radon egress, it is suggested that the details given in Positive pressurisation: a guide to radon remedial measures in existing dwellings may be considered.