

TECHNICAL SPECIFICATIONS	
Power Supply	
Rated Current	
Motor Rating	
Frequency	
Revolutions per Minute	
Max. Vertical Output	
Max. Horizontal Output	
Max. Flow Rate	
Max. Liquid Temperature	
Discharge Size	
Cable Length	
Weight	
Colour	

ACCESS COVER (CLEAR OPENING)		
LENGTH (mm)	WIDTH (mm)	TYPE

FABRICATION SPECIFICATIONS				
ITEM	INDEX	DEPTH (mm)	DIAMETER (mm)	CLOCK FACE POSITION
Tank depth	A			
Tank diameter	B			
Inlet	C1			
Inlet	C2			
Inlet	C3			
Inlet	C4			
Discharge	D			12
Slab (inc. cover)	E			
Cable Duct				

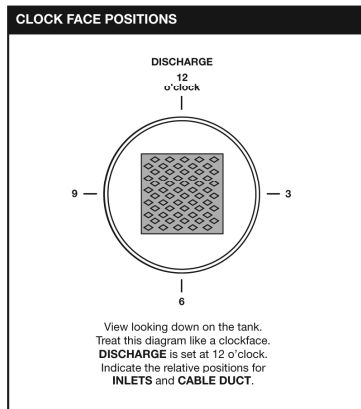

SUMPFLO – Technical Drawing

(Central drainage pipework – screeded floor)

SHOULD YOU REQUIRE TECHNICAL ASSISTANCE
CONTACT OUR HELPDESK ON 0845 123 6006 OR
EMAIL TO mail@twistfix.co.uk

COMMENTS:

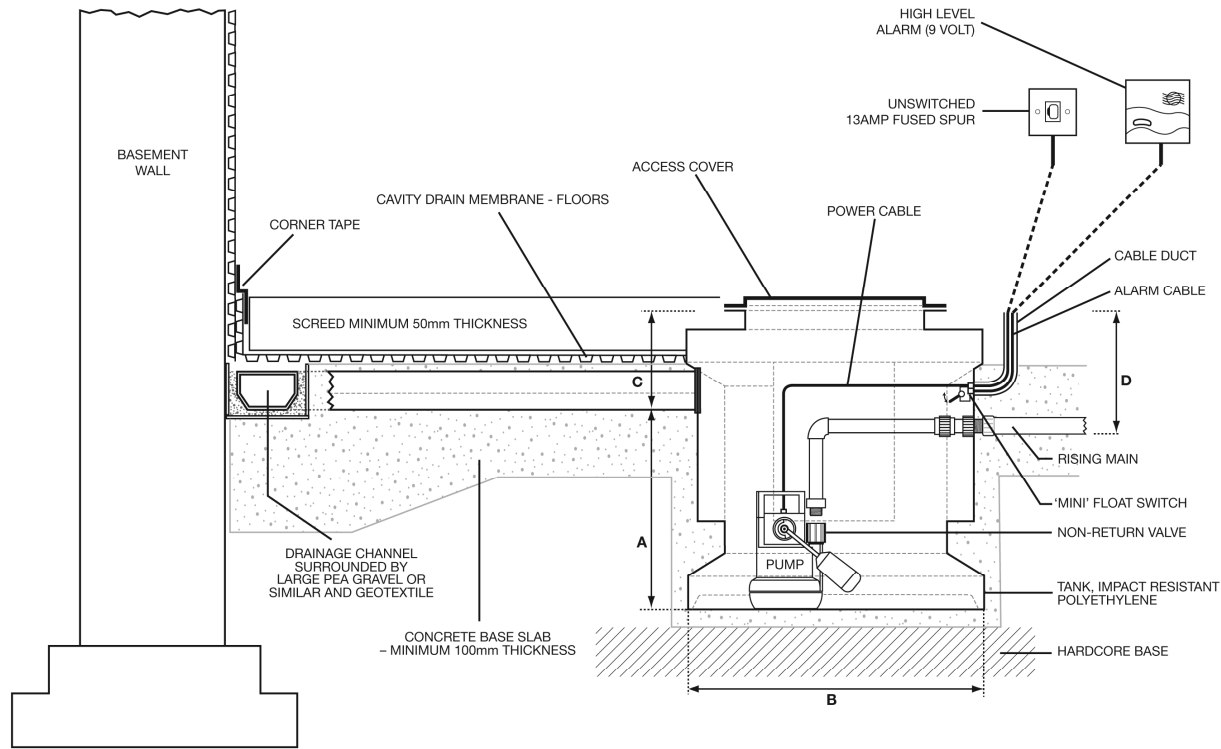

SIDE ELEVATIONS

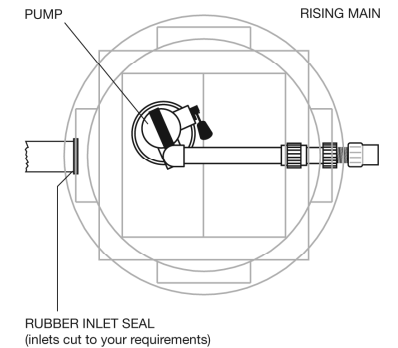

PLAN VIEW

PLEASE NOTE THAT THIS DOCUMENT MUST BE READ IN CONJUNCTION WITH THE INSTALLATION & OPERATING GUIDELINES. DRAWING NOT TO SCALE.

CUSTOMER NAME	PRODUCT NAME
PROJECT NAME	DRAWING VERSION
PROJECT ADDRESS	DATE
	DRAWN BY
	CHECKED BY

Twistfix Group

81 Oxford Street
London W1D 2EU

6th Floor, 8 Exchange Quay
Manchester M5 3EJ

Tech Tel: 0845 123 6006
Sales Tel: 0845 123 6007

Email: sales@twistfix.co.uk
Web: www.twistfix.co.uk

